

LGate 101

RESIDENTIAL SOLAR MONITORING SOLUTION

Locus Energy's LGate 101 is a revenue-grade energy meter and web-enabled datalogger for monitoring residential solar photovoltaic systems. It is designed to collect, store and upload a wide array of energy data allowing both system installers and owners to efficiently manage solar assets.



The LGate 101 can monitor nearly any type of solar energy system. Regardless of inverter or panel type, it can measure energy production with a high degree of accuracy. As a datalogger, it has a variety of digital and analog inputs enabling direct communication with third-party devices such as inverters and meteorological sensors. Performance data is aggregated and uploaded automatically to the Locus Energy Smart Monitoring website which provides custom tools and analytics to all project stakeholders.

DATA COLLECTION

The LGate uses a hard-wired voltage reference and current transformers (CTs) to measure power. There are inputs for up to three CTs allowing the LGate to measure both solar energy generation and whole-house electrical consumption. It can also gather data from up to 16 third-party devices simultaneously which is collected via RS485 and Modbus RTU protocols. All data feeds are stored in non-volatile memory and then uploaded with unique identifiers to provide maximum flexibility as to how the data is presented online.

NETWORK CONNECTIVITY

The LGate 101 is a plug and play device supporting a multitude of connectivity options. It can communicate over Ethernet, powerline carrier (PLC), or cellular networks. Hard-wired Ethernet is the preferred connection method, but if this is unavailable, the LGate features a built in 110V outlet for easy installation of a PLC adapter. Data is transmitted only in outbound sessions over open ports requiring no additional network or firewall configuration. The connection and commissioning process is further simplified by the LGate's LED lights which indicate communication status without installers having to log in or call home.

ABOUT LOCUS



Locus Energy develops web-based asset management software for renewable energy systems. We provide monitoring, analytics and data services for deployments of solar photovoltaic and solar thermal technology. By leveraging Locus' products, renewable finance companies and integrators can drive down the cost and complexity of energy monitoring while making it much easier to maintain and service an installed client base. Founded in 2007, Locus is based in New York City and serves clientele across the world.

SOLUTIONS



Locus Energy offers Smart Monitoring software services tailored to the following groups to help maximize the performance of renewable assets:

- Installers
- Financiers
- Utilities
- OEMs
- Regulators

DIAGRAM – TYPICAL CONFIGURATION

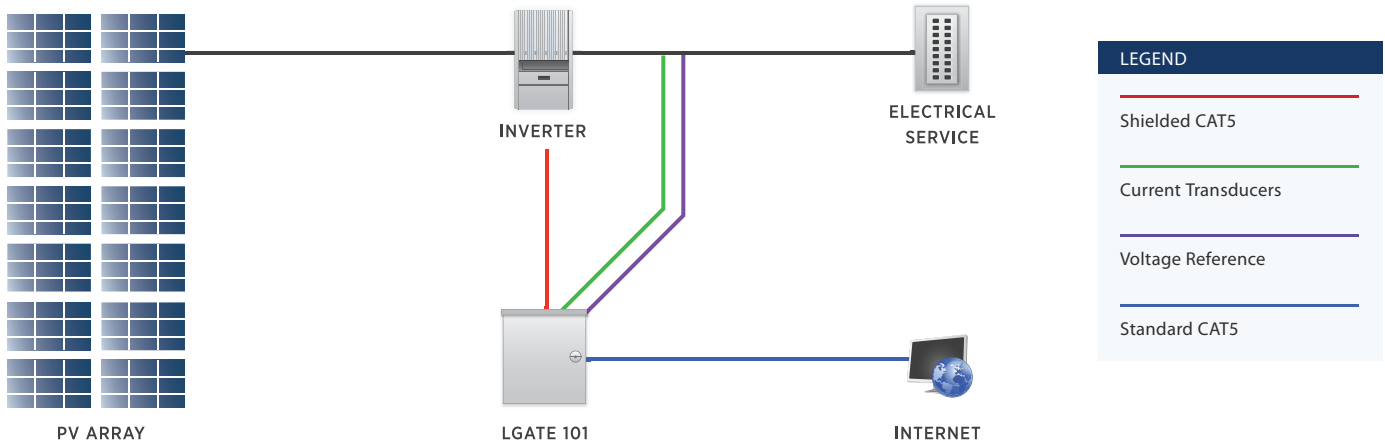

DIMENSIONS

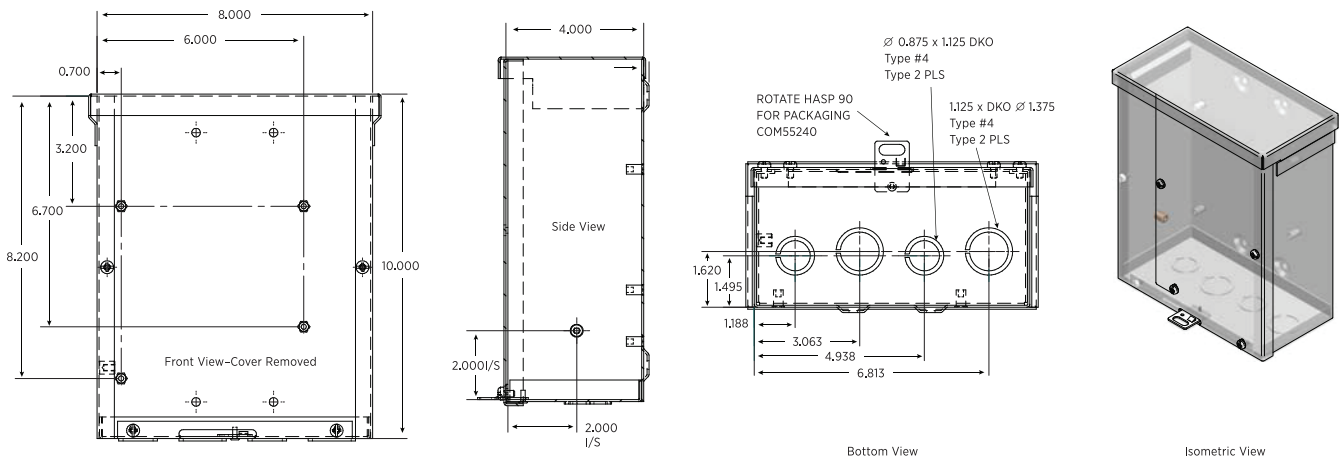

SPECIFICATIONS

DATALOGGER	
Processor	ARM9 embedded CPU
OS	Custom version of Linux 2.6, OTA firmware updates
Memory	128 MB RAM
Logging interval	1 to 60 minutes, user selectable (default 5 minutes)
Display	USB-based handheld LCD (optional)
I/O	
RS485 2 wire and 4 wire terminals	
Modbus	
USB	
KYZ Pulse	
4-20 mA analog	
COMMUNICATIONS	
LAN	RJ45 10/100 Ethernet, full half duplex, auto polarity
Cellular	GSM/CDMA
Add-ons	Powerline carrier, Zigbee
Networking	DHCP or static IP

POWER METER	
Voltage Inputs	85-264 V Line To Neutral or Line to Line
Phases	Single phase, Split phase at 50 or 60 Hz
Current Inputs	mA Solid-Core CTs 200 Amp .75" internal diameter, mV Split-Core CTs 200-600A, up to 1.25" internal diameter
COMPLIANCE - Certified by TUV Rheinland of North America (NRTL)	
ANSI C12.20 0.5%	
IEC 61010 (Safety)	
FCC 15 Part B	
IEC 60068-2-2 7 (Mechanical shock)	
IEC 60068-2-6 (Mechanical Vibration)	
CFR 47 ANSI C63.4 (Radiated emissions)	
CAN/CSA - C22.2 (61010-1)	
PHYSICAL	
Enclosure	NEMA 3R Type
Weight	6 lb 12 oz
Dimensions	10" x 8.25" x 4.25"
Environment	-20 to 70C, 95% RH, non-condensing
Warranty	5 year limited warranty for power-meter, data logger